



TES-i

ENGINEERING A SAFER TOMORROW



# TES-i Overview

*Since 1997, delivering complex Electronic and Software Solutions to U.S. Military and Industry*

*2.3+ Million Engineering Hours*

Active member for the Southern Arizona Aerospace and Defense Cluster  
Contributing member of the FACE consortium and Technical Standard  
Active member of the SOSA consortium  
Active member for the Arizona Technology Council of CEO's

DUNS: 019000137

CCR/CAGE/NCAGE: 1KNK1





# COMPANY OVERVIEW

TES-i creates cost effective, highly reliable, safe and secure solutions of enterprise and embedded hardware and software systems through exceptional design, development, integration and verification.

- Founded in 1997; Approximately 70 employees with 75% holding engineering degrees
- ISO 9001:2015/AS9100D certified, AS9115 compliant
- Supplier to the top 7 OEMS in Defense and Industry

## ***Our Vision:***

***To improve peoples lives through innovative, rapid, reliable, safe and secure system solutions.***

## ***Our Mission:***

***We will deliver innovative engineering solutions, methods and tools that accelerate the development and delivery of reliable, safe, and secure products for industry and government customers meeting the most stringent of standards.***



### **Company Headquarters Engineering Center**

5620 N. Kolb Road Suite 160  
Tucson, AZ 85750  
(520) 575-7283

22,500 sq ft Office/Secure Laboratories



### **Manufacturing & Laboratories**

3431 E. Hemisphere Loop  
Tucson, AZ 85706  
(520) 741-2144

11,000 sq ft Office/Manufacturing Facilities  
Including Prototype Machine Shop



### **Digital Engineering**

7501 S. Memorial Pkwy SW,  
Suite 218  
Huntsville, AL 35802  
(256) 213-7657

### **TES-i Subsidiary – MBSE Tools & Services**



5620 N. Kolb Road Suite 100  
Tucson, AZ 85750  
(520) 498-0490

# TES-i Board of Advisors



**Major General (Ret.)  
Tim Crosby**



*MG(R) Tim Crosby retired from U.S. Army as Program Executive Officer for Aviation*

**Thomas R Cunningham**



*Senior Executive with extensive, expertise in US Domestic and International sales and program management. Cooperating with senior leadership from multi-national corporations to achieve sales of military and commercial products to US and International military services.*

**Jeffrey L. Langhout**



*Served as a Department of the Army civilian for more than 37 years with his last assignment as the Director for the U.S. Army Combat Capabilities Development Command Aviation & Missile Center (DEVCOM AvMC), where he led a workforce of more than 11,000 engineers, scientists, researchers and support.*

**Wayne Brown**



*Quality, Engineering, and Operations with a demonstrated history of results in the Aviation & Aerospace industry. Skilled in Coaching, Production Execution, Strategy, Management, Leadership, and Team Building.*

# How we help our Customers?



## Partnership:

Since 1997, TES-i has been recognized as a cost-efficient integrated solution partner for many Customers across several industries including Aerospace, Mining and DOD. Our program and technical staff have been working directly with development teams to solve challenges in key areas such as line replaceable units, test equipment, BSP, and avionics integration.



## Work Site:

TES-i performs most of our work at one of TES-i's locations on our computers and using our facilities. We have often hosted Customers at our site for various meetings, testing events, and even storage. TES-i will spend any amount of time on an individual Customer's site for meetings, deployment and test to ensure that the project is successful.

## Intellectual Property:

TES-i has just celebrated our 25<sup>th</sup> anniversary protecting our Customer's Intellectual Property. While we do have our own products and patents, we are cognizant of the work for hire relationship and will work to grow the Customer's IP staking no claim to improvements.



# Exceptional Engineering Services



## Quality:

Our Customers expect high-quality work that meets their needs and exceeds their expectations. This includes delivering projects on time, within budget, and to the desired specifications. TES-i delivers Quality.

## Expertise:

Customers want to work with engineers who have the necessary skills, knowledge, and experience to successfully complete their projects. They also want engineers who are up-to-date on the latest technology and industry developments. TES-i has those engineers.

## Communication:

Clear and open communication is crucial for successful engineering projects. Customers want engineers who are responsive, accessible, and able to explain technical concepts in a way that is understandable to non-experts. TES-i consistently communicates accurate and informative status.

## Cost-effectiveness:

Customers want to receive value for their money, which means that engineering services should be cost-effective and offer a good return on investment. TES-i delivers real ROI.

## Innovation:

Customers are often looking for engineering services that can bring new ideas and innovative solutions to their projects. This may involve finding new ways to solve problems, using cutting-edge technology, or developing more efficient processes. That is what the "I" in TES-i stands for.





# TES-i Market Focus

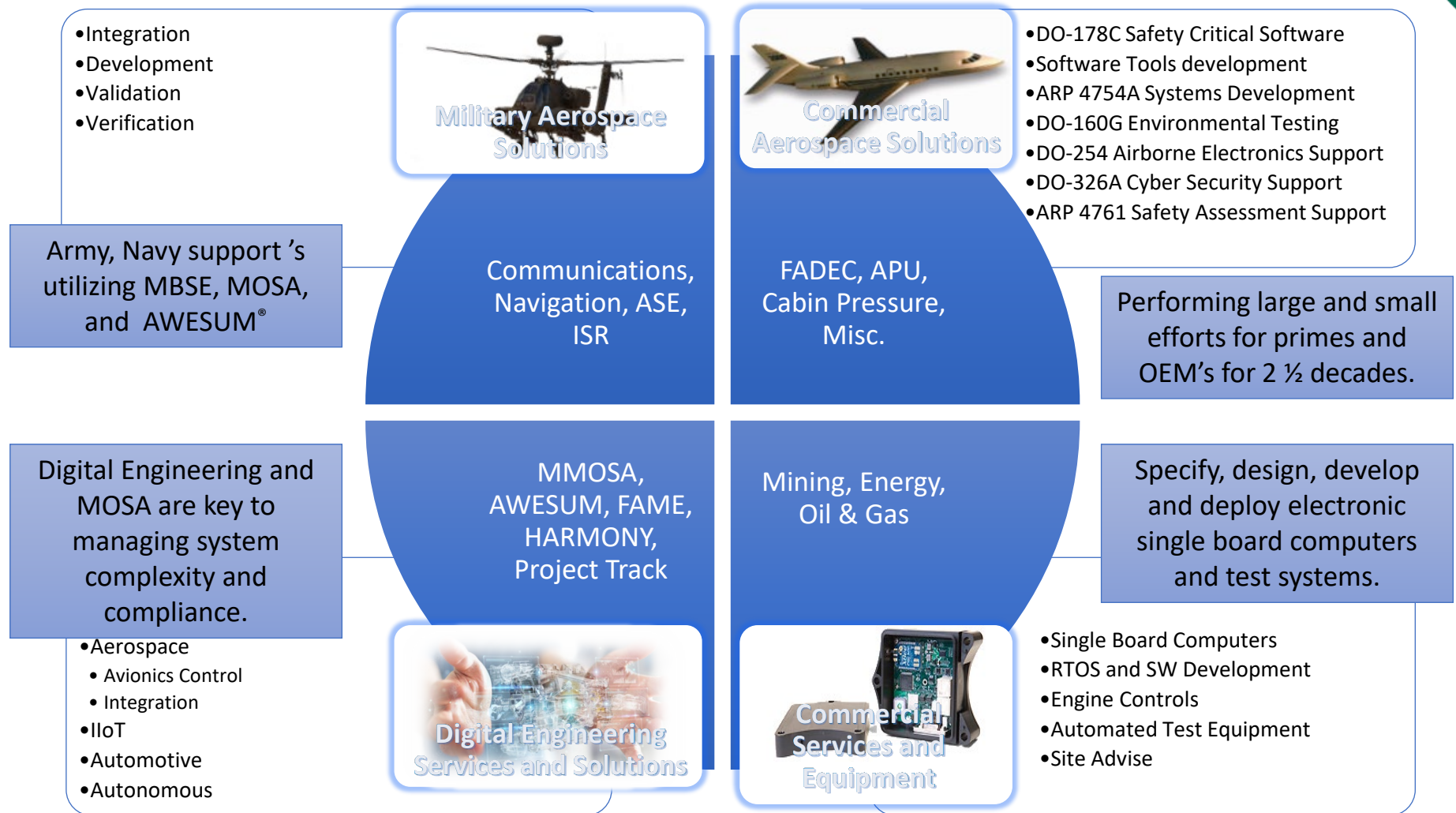

# Current Customers

## ***Government Customers include:***

- Army PEO AVN, A2E2, CCDC-AvMC, AACDC-AMC-TDD-A
- Army Ft Huachuca Intelligence COE (CECOM, IBL, NSTID)
- Aerojet Rocketdyne (Preferred Supplier)
- Booz Allen Hamilton
- Elbit Systems of America, ESA
- Georgia Tech Research Institute (GTRI)
- Lockheed Martin Corporation
- NASA Jet Propulsion Laboratory (JPL)
- Northrop Grumman Systems
- Navair
- Piasecki Aircraft Corporation (PiAC)
- Raytheon Missile Systems (RTX)
- SAIC
- Vertical Lift Consortium (VLC)

## ***Commercial Customers include:***

- AeroVironment
- B/E Aerospace (RTX)
- Caterpillar
- Hamilton Sundstrand (RTX)
- Hexagon
- Honeywell (Preferred Supplier)
- Modular Mining (Komatsu)
- Securaplane (Meggitt)
- Seeing Machines





# Recent Projects

- Model Based Systems Engineering (MBSE)& Tooling
- System and Software Engineering Services
- MOSA Radio Control Software Development & Verification
- Tactical Radio Control System
- Avionics device control and integration
- Camera Systems Design and DO160
- Video Software Development
- System / Production Test Equipment
- Power Relay System for Large Vehicle
- HARMONY – HOST (OpenVPX) conformance test suite (Navy Phase II SBIR)

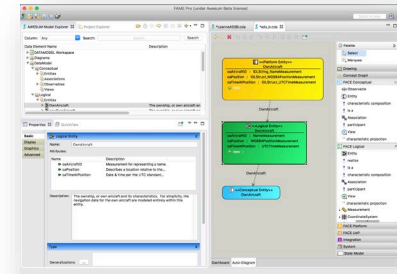

# Safety and Mission Critical Software

- 26 Years of DO178 Software Development including DO-330, DO-331, DO-332
- FAA DO-178C, DAL A – D; PSAC through SAS
- Safety Analysis and Traceability Analysis
- Tool Qualified Automated Test Systems
- 18-years supporting US Army's Common Software Initiative (CSI), 6-years active FACE Consortium Member, Industry-only FACE VA, 2014
- Authored Program Manager Handbook for Software Safety (PMHSS)
- Authored "US Army PM-AME Policy and Procedures Lifecycle Management Acquisition", 2009
- Authored "Developer's Handbook for Airworthy, Reusable FACE Units of Conformance", 2014



- Full Authority Digital Engine Controllers (FADECs)
- Cabin Pressure Control Systems
- Cockpit Instrumentation
- Smoke Detection and Suppression
- Auxiliary Power Unit Control
- Flight Management Systems
- Emergency Cabin Oxygen Control System
- Radio Control and Integration
- Power Systems



# Software Development



- DO-178 Level A-E and DO-254
- FACE Infrastructure, Data Modeling, and UoP Dev
- Real-time Embedded Software
- Bare-bones, RTOS and FPGA systems
- Experience with all OS software from FreeRTOS to VxWorks to Linux
- Control Systems and Avionics
- Real-time data acquisition and instrumentation
- CCD image acquisition
- Enterprise and Windows Applications
- Cloud Computing and Mobile devices



- Full Authority Digital Engine Controllers (FADECs)
- Radio Control and Integration
- Power Systems
- Camera and Fatigue Systems
- Battery Systems
- Navigation
- RF Mesh Control





# Electronic Design



- Computer Board Design and IO Circuitry
- Board Support Packages including Device Drivers
- OS integration and application architecture
- Real-Time Embedded Applications
- Analog and Digital Data Acquisition
- Sensor Integration and Mesh Networks
- Simulation, Modeling and Application Development
- Automated & Manual testing
- Enclosures and Cabling

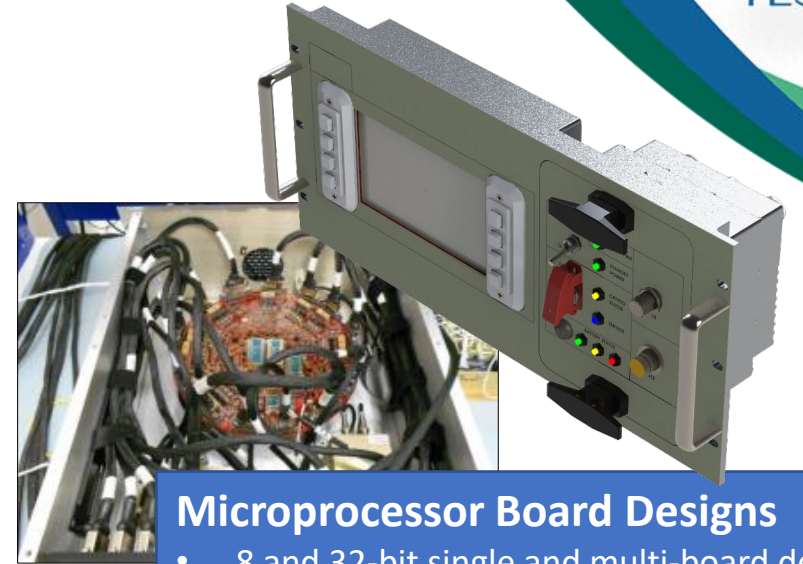

## Microprocessor Board Designs

- 8 and 32-bit single and multi-board designs
- High density embedded designs
- Embedded controller module-based designs
- High speed signals, Programmable Gain Amplifiers, Transient Protection, Power Supplies, USB and Ethernet
- Bus backplane design
- FPGA with nanosecond response times, with burned in 32-bit Microprocessors
- Custom Hardware Interface Sub-Systems
- Custom VME and ISA cards
- Multi-I/O interface conversion cards

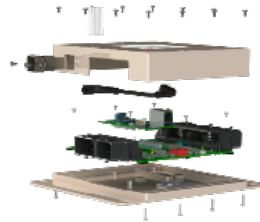
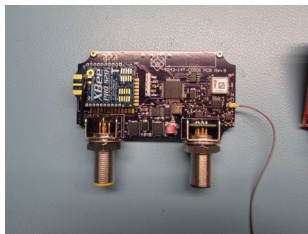

# Line Replaceable Unit (LRU) Solutions

- TES-i develops concepts for various industries in collaboration with our customers
- Designs the electronics, enclosure, mechanical and cabling
- Develops firmware, software, test harnesses, cloud communications and documentation
- Prototype, procure, redesign for availability, and build LRIP units
- Create test equipment, test and Environmental Stress Screen (ESS)
- Validate, verify and deploy
- TES-i will support and manage core obsolescence.

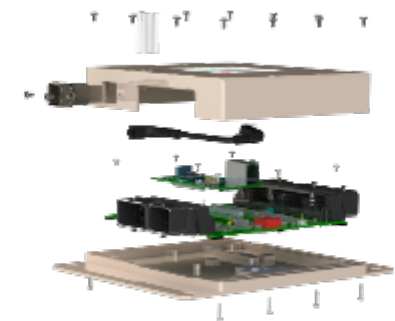
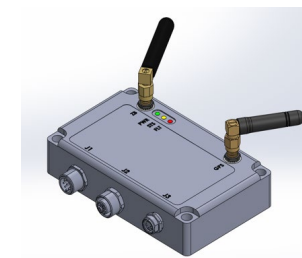
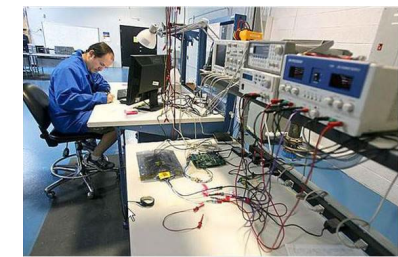

# Prototype Machine Shop

- ❖ Metal, Wood & Plastic
  - Manual Vertical Mill 9x42"
  - Manual 13x40" Lathe
  - Drill Press



- ❖ Metalworking
  - TIG Welding
  - MIG Welding
  - Plasma Torch
  - Brake/Sheer/Roller



- ❖ Automotive
  - 2 Post Lift (10k lbs)

- ❖ CNC
  - Tormach Mill
  - Tormach Lathe
  - Laser Cutter / Engraver



- ❖ Shop Services
  - Shop Air
  - Power 110/240/480 1-3ph.
  - Oven
  - DC Power Testing

- ❖ Finishing Work
  - Sand/Prep
  - HVLP Spray
  - Powder coat

- ❖ Layout
  - Granite Table
  - Welding Table
  - General Workbench



# Automated Test Systems

Development of automated test equipment and automated test scripting reducing cost and schedule through Auto-generation of software code, test cases, procedures, and documentation.



- Real-Time Embedded Testing against Requirements
- Open Loop, Closed Loop, ATP on Target and Simulator including Structure Coverage
- Use of COTS (Agilent and National Instruments)
- Automated scripts in Python, LabVIEW, etc.
- Expansive and Capable Labs
- Design Documentation
- Self Test Procedures
- Maintenance Documentation



# TES Testing Experience

## Hardware, Software, and System Test

- Automotive and Aerospace Test Equipment
- DO-160 and MIL-STD-810D ESS
- Military Communications and Simulations
- Army Military Intelligence Systems
- Full authority digital engine controllers (FADECs)
- Auxiliary Power Units (APUs)
- Cabin Pressure Control Systems
- Data Analysis Tools

**Core Competencies:**

- Mission and Safety Critical Systems
- Real-Time Embedded Testing
- Aerospace (DO-178B) V&V including Environmental and Qualification Testing
- Automated Test Systems Development and Use including Scripting (Custom & Build-to-Print)
- Open Loop, Closed Loop, ATP on Target and Simulator including Structure Coverage
- National Instruments Alliance Partner using LabVIEW

**Extensive Test Design, Development, and Documentation Experience:**

- Safety and mission critical systems; particularly aviation and missile systems
- Commercial and military embedded systems and software
- Development, operational, and production testing and test support
- Qualification to FAA DO-178B and DoD airworthiness requirements
- Developed Programmable Control Test System to test embedded controllers

**Sample Systems Tested:**

- Full Authority Digital Engine Controllers (FADECs)
- Aviation diagnostic and prognostic systems
- Commercial Cabin Pressure Control , Emergency Oxygen, and Smoke Detection/Suppression Systems
- Auxiliary Power Units (APUs)
- Completed over 150 test projects and 500,000 test hours for single customer

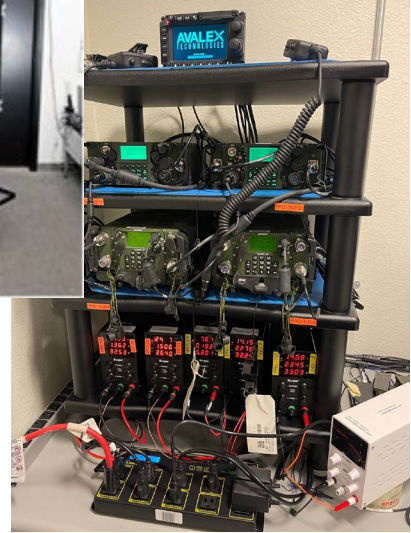

# Enterprise Applications Development

- Service Oriented Architecture design & development
- Expertise in Java, C#, C/C++, & Javascript
- UI implementation:  
Web (Angular), .NET, Java, and TCL
- DBMS: Database design and maintenance (SQL, Oracle, OrientDB, Cloudbase, etc.)
- Hadoop/Storm streaming architectures
- Camel & Spring
- Expertise in automated testing processes
- UI design:
  - Timelines
  - Structured Graphics
  - Raster Graphics
  - Geographic Information Systems (GIS)
  - ...





# Integrated Solution Partner

- System Design
- Circuit Design
- Circuit Card Prototypes
- Board Support Packages
- Real-time, Fault Tolerant Software Design
- Software Development and Test
- Mechanical Enclosures and Systems
- Hardware and Software Integration and Verification
- System Performance Analysis
- Production Test Equipment

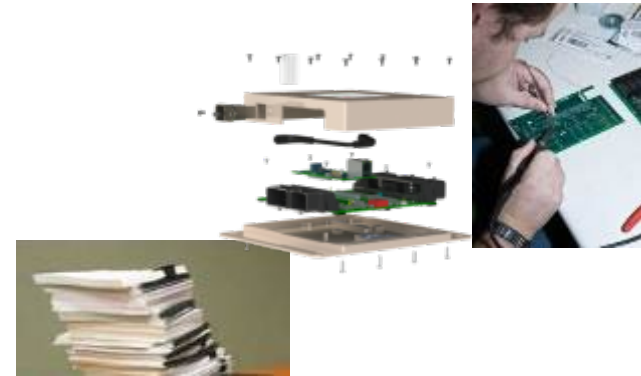
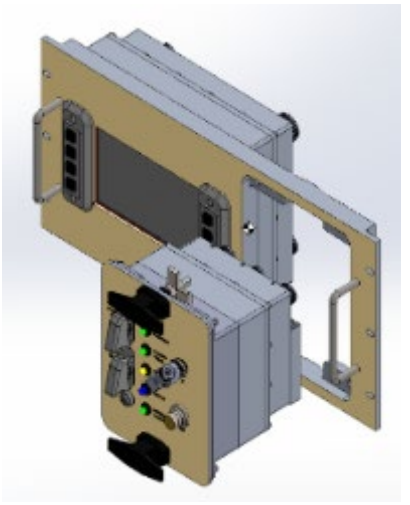
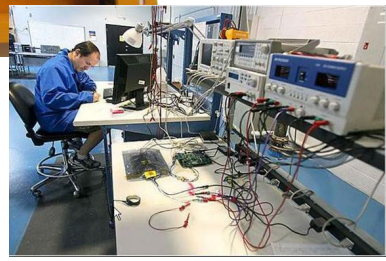
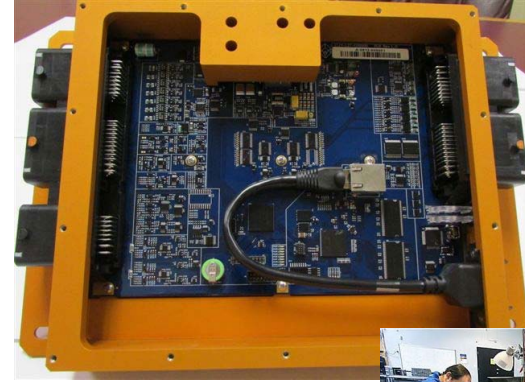

Requirements   Design   Prototype   Test   Production

# Hydraulic Relay Assembly

## Objective:

To design, develop, manufacture, and verify a custom Relay Driver for the launch vehicle hydraulics.

## Outcome:

- **Maintain Wiring Harness with additional Automatic Circuit Breakers and Fusing**
- **Reduce weight from hundreds of pounds to ~75 lbs**
- **Reduce size/volume by 65%**
- **Decrease System costs and Increase longevity**
- **Custom Circuit Card Assembly**
- **Combined Mechanical Relay, Solid State Relays, and FET based PCB design.**
- **Physical and Logical separation of AC/DC electrical subsystems**
- **Software Diagnostics**
- **Exhaustive Test Stand and ATP Documentation**
- **Engineering Environmental Testing**

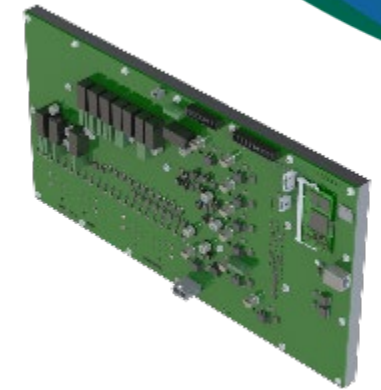

# Driver Fatigue Safety Monitoring

## Objective:

To design, develop, manufacture, and verify custom electronics, optics, and mechanical systems to support the integration of customer software used for automotive driver safety

## Outcome:

- **Select and Develop main processors and power management circuitry.**
  - Selection and Integration of Cellular, WiFi, Bluetooth Antenna
  - Selection and Integration of USB Host, USB OTG, Serial, Ethernet, CAN, Flash, LED drivers, etc.
- **Select and Develop optical paths, high resolution cameras, lenses and LED lighting capabilities**
- **Design mechanical enclosures, and documents for prototype and LWIP manufacturing**
- **Design and Develop internal and external harnesses**
- **Evolve customer reference designs**
- **Develop additional processors and comm. protocols**

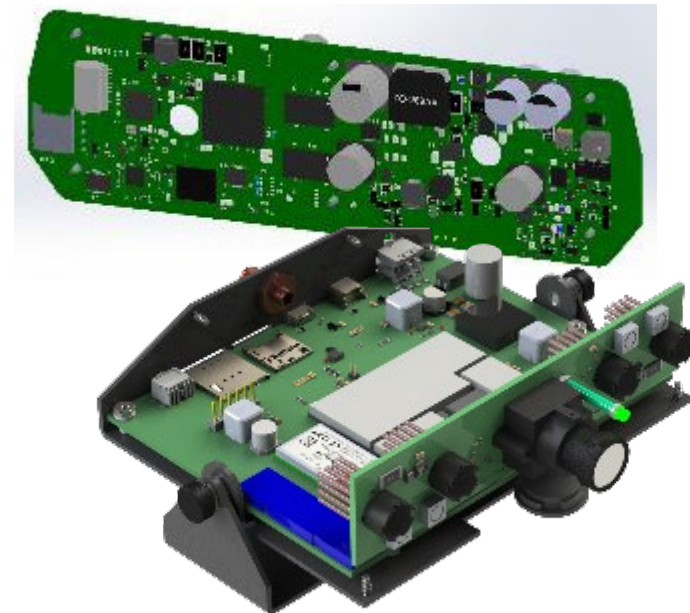
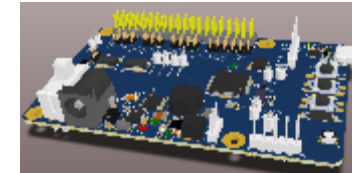



# Signal Processing

**Objective:**

To develop software and test equipment to implement and verify cutting edge 5G capabilities.

**Outcome:**

- Reduce transmitter SI (signal interference) in the receive path by 110dbm
- SI reduction budget by stage
- Stage 1: MRA (multi-mode re-configurable antenna). Reduce SI by 35dbm to 40dbm
- Stage 2: Analog RF Canceler circuit. Reduce SI by 15dbm to 20dbm
- Stage 3: Digital canceler in the receive data path. Reduce SI by 60dbm or more.

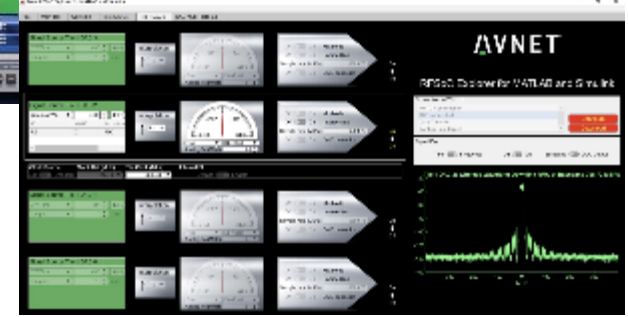
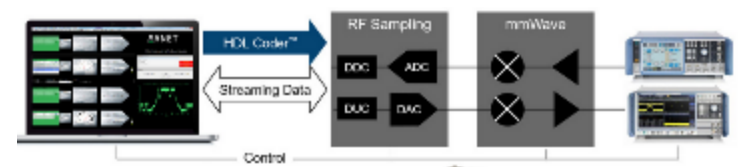
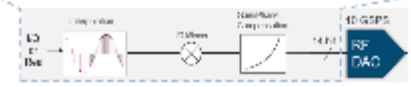
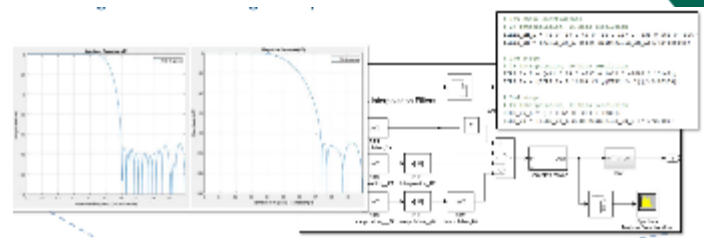

# What is Digital Engineering?

An integrated digital approach that uses authoritative sources of systems data and models as a continuum across disciplines to support lifecycle activities from concept through disposal.

- Digital engineering describes a holistic approach to the design of a complex system:
  - **Design using models**/data instead of documents
  - **Integration** of data across models
  - A **culture change** across project teams to realize significant risk reduction on construction cost and schedule
- Modular Open Systems Approach (MOSA) is an acquisition and design strategy focused on building systems that are composed of modular components that are open in nature.

### MOSA Objectives

- Efficient modifications to support continuous delivery of capability (***Adaptability***)
- Faster fielding of innovation (***Overmatch***)
- Total lifecycle affordability and resiliency (***Competition***)
- Increased interoperability; reduced qualification and sustainment burden; and compliance with all statute, policy, and regulatory requirements (***Commonality***)

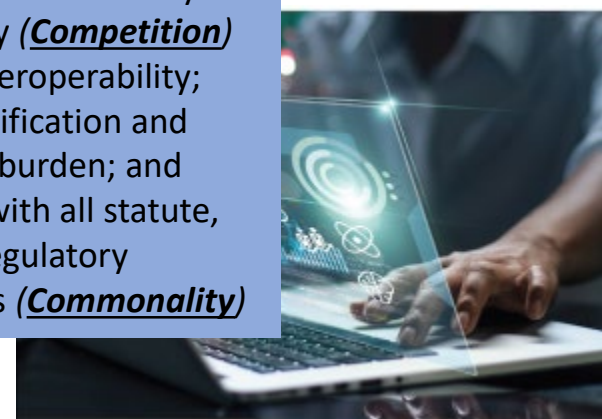

# Digital Engineering solutions with MMOSA & AWESUM

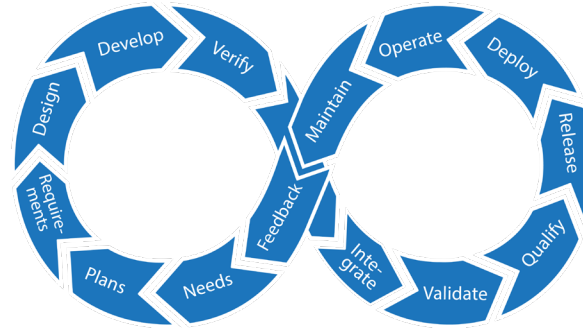
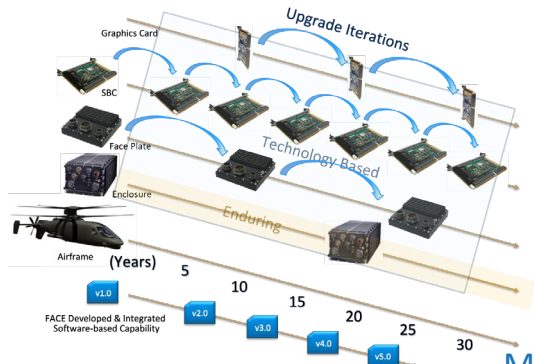

Model-based Modular Open Systems Approach (MMOSA)

AWESUM is built to support systems development utilizing emerging standards

<p><b>SOSA</b> Sensor Open Systems Architecture</p> <p>Sensor Open Systems Architecture (SOSA™)</p> <ul style="list-style-type: none"> <li>• OpenVPX</li> <li>• Sensors</li> <li>• Networking</li> <li>• Software Interfaces</li> <li>• Messaging</li> </ul>	<p><b>HOST</b></p> <p>Hardware Open Systems Technologies (HOST)</p> <ul style="list-style-type: none"> <li>• OpenVPX, others</li> <li>• Future: Other Embedded computing architectures</li> </ul>	<p><b>CMOSS</b></p> <p>C4ISR/EW Modular Open Suite of Standards</p> <ul style="list-style-type: none"> <li>• C4ISR, EW and platform interoperability</li> <li>• Network data bus</li> <li>• Sharing of services i.e., Time, Position, Orientation</li> </ul>	<p><b>FACE</b> Future Airborne Capability Environment</p> <p>Future Airborne Capability Environment (FACE™)</p> <ul style="list-style-type: none"> <li>• Operating System APIs</li> <li>• I/O interfaces</li> <li>• Messaging APIs</li> <li>• Data Architecture</li> </ul>
--	---	--	--

Many other Open Standards such as WOSA, MORA, VICTORY are leveraged for MOSA



# Why Digital Engineering, MOSA and MBSE matter?

- The promise of drastically reducing **Risk, Cost, and Schedule** of developing complex Cyber-physical systems.
- U.S. government departments are focused on **advancing Systems development** using Digital Engineering and supporting MOSA & MBSE technologies.



## Purpose

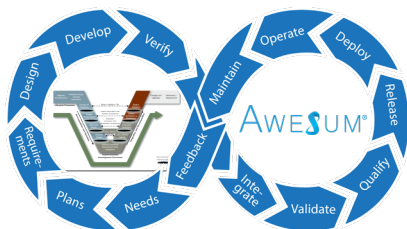

**SAVi** is focused on developing processes & tools for **Digital Engineering** with the approach of optimizing the Systems Development process to reduce effort, schedule and cost while increasing quality and supporting emerging standards.

## Services, Training, and Support



- SME and Product Development Services
- **FACE** Verification Authority
- Aviation Engineering Services for Airworthy Qualification Efforts
- Model Based Engineering
- FACE Data Architecture Training
- FAME Training
- AWESUM Training
- AWESUM and FAME help desk

## Products



The AWESUM Product Suite is a toolset for **Commercial and Military Aviation Software Intensive Systems Development & Certification**. AWESUM is a comprehensive model-based environment aligned to DO-178C, DO-331, AC 20-148, AR 70-62, and FACE™ supporting the full complement of models for managing the source of truth for all project data.



AWESUM **FAME** is a FACE Data Architecture Modeling Development Environment providing intelligent automation saving thousands of modeler hours.



Harmony is a Test Station for Systems, Hardware and Software verification supporting standards conformance testing such as HOST and FACE.

DUNS: 117442912

CCR/CAGE/NCAGE: 8MTK8



Enables Digital Engineering Solutions for complex cyber-physical systems through a smart and highly functional design:

- **Optimized** solution for MBSE Development Lifecycle: four systems-engineering domains:
  - Requirements/capabilities
  - Behavior
  - Architecture/structure
  - Verification and validation
- Solutions satisfy the **Needs** of the System as well as the requirements
- Focuses on **reliable** (safe & secure) **reusable** solutions
- Standards Based **MMOSA** Process Support
- Continuous Development, Integration, Deployment Support (CI/CD)
- **Systems Unified Model (SUM)** leveraging "Big Data" technologies
- Advanced **Auto-Generation** of Documentation, Code, and Test

Leading the way for Army Digital Engineering Solutions



# Digital Engineering

**Challenge:**

DoD is focused on Digital Engineering and reaping the promised benefits. Unfortunately, the processes, standards, tooling, and training lag behind the need.

**Solution:**

- TES and TES-SAVi are focused on optimizing the systems engineering process and tooling for digital engineering.
- TES-i will leverage our US Army PEO Aviation experience with CDA, CAM, WDI, MOSA, UAI, R2C2 since 2003.
- TES has the capability to:
  - Develop Data Model from current ICDs or build ICDs from requirements
  - Auto generate 86% of the code for communications and control
  - Auto generate automated testing scripts
  - Implement WOSA and UAI.
- TES-i can develop various simulators to support development and integration.

**Example:**

- ARCM (TES product development for Army Aviation) to produce the Army's Airworthy FACE Communications Manager built with AWESUM®.

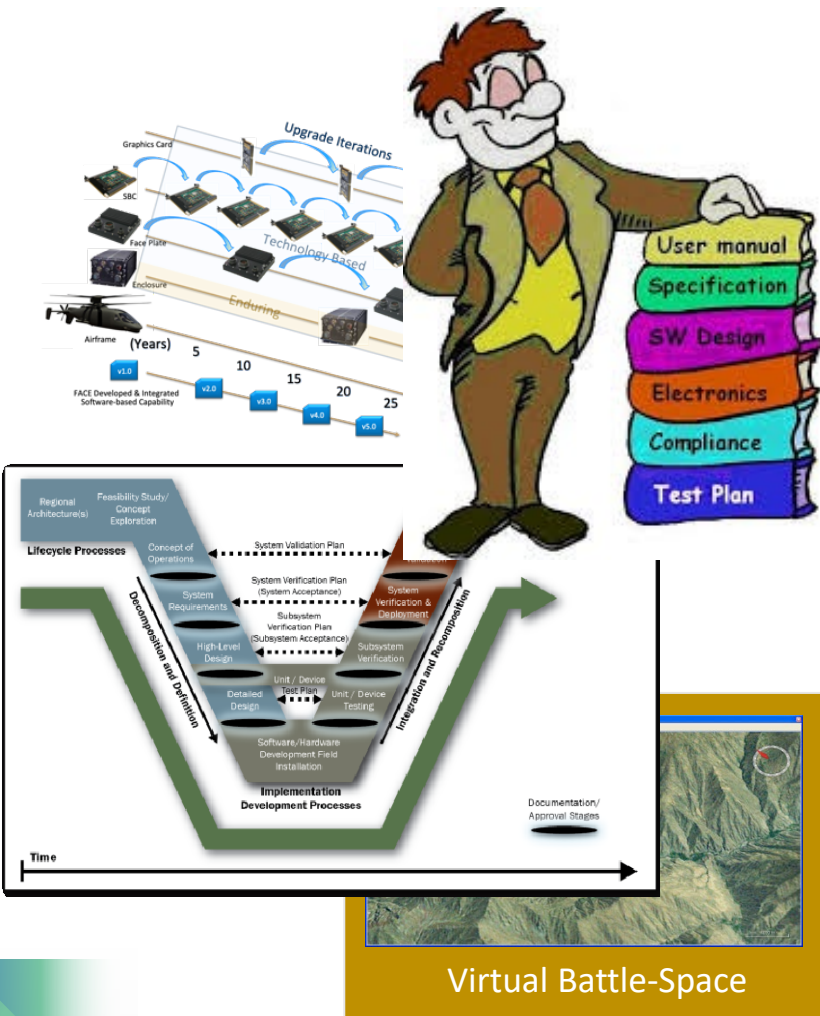

# TES-i's U.S Army's ARCM, FACE 3.1, DO-178 DAL-C with DO-331 MBSE



- ARCM is a set of reusable platform portable software components for both legacy and next-generation radio systems onto Army Aviation platforms.
- The ARCM software is FACE™ Safety Base Profile, edition 3.1, with DO-178C DAL-C guidance, and is developed using TES-SAVi's AWESUM® model-based tool suite.

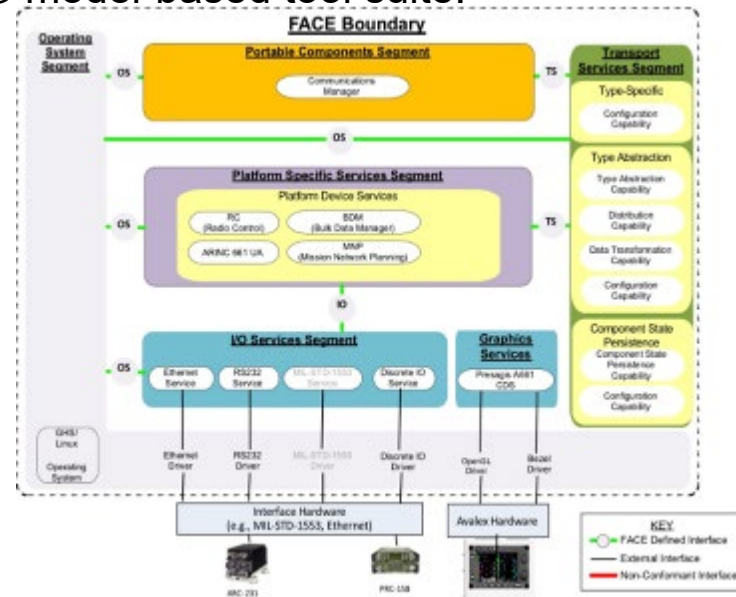



TES-i

# TES-i's FACE 3.1 COE Link Libraries



- TES-SAVi developed FACE Common Operating Environment (COE) Link Libraries, which are being transferred to the U.S. Army with Government Purpose Rights (GPR)
- The COE is a set of reusable platform portable software components for FACE TSS, OS, and IOSS, and services
- The Link Libraries are FACE edition 3.1, are aligned with DO-178C DAL-C guidance and are developed and sustained using TES-SAVi's AWESUM® model-based tool suite.

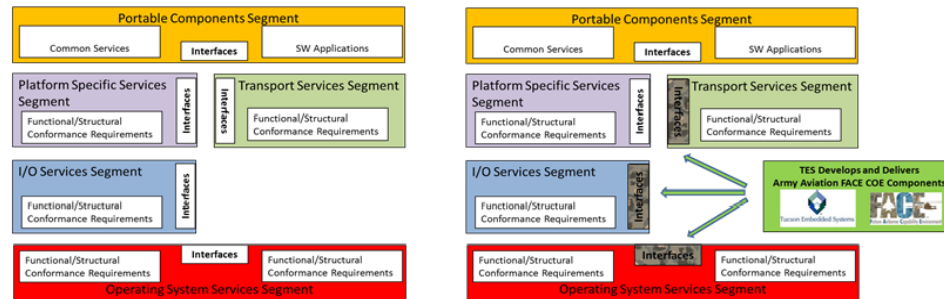



# TES-i Solutions – MCOTS for quick success



## IDEC™ Industrial Digital Engine Controller

- Used for mining, oil and gas, industrial, electrical power, and hydraulic power generation
  - TF-40: 4600HP used on Navy LCAC
  - T55: refurbished Army Chinook turbines
  - T53: refurbished Army Huey turbines



## TESseract™ FACE™ Processing Center

- Rugged airworthy flight control or general-purpose LRU
- Robust redundancy and networking
- Fiber Optic based Mil-1394 (AS5643) comm bus
- Provides a FACE™ operating environment



## SITE ADVISE™ Wireless Mesh Network Remote Sensor & Control Management System

- Self Healing Mesh Radio Network with GPS tracking with remote sensing and control
- Monitors and Controls hundreds of deployed assets
- 802.15.4 ZigBee Technology
- 1 Control Gateway with Multiple Nodes



## SMART CABLE™ Digitizes the physical edge over ethernet to reduce size and weight

- Current Loop Inputs and Outputs (4-20mA)
- Relays (2-7 Amps)
- Analog Inputs and Outputs (0-10VDC)
- Built-in GPS Location Monitoring



## HARMONY™ MOSA Conformance Test Station

- OpenVPX Test hardware (HOST, SOSA, CMOSS)
- FACE™ functional interface, UoC and Data Architecture verification
- Streamlines the conformance process
- Full Traceability & auto documentation of artifacts
- DOORS Integration



## TRCS™ Tactical Radio Control System

- Configure and Control IP Mesh Radio Network with remote messaging and HMI Display
- Monitors and Controls various nodes attached to tactical assets
- 802.11 IP Technology on various encrypted frequencies

# TES-i Turbine Engine Controller

According to Reuters (July 2013), "Bakken flaring burns more than \$100 million a month"



Gas Turbine Engine



+

Generator

=

High Power Density Power Generation



TES developed first multi-fuel turbine controller (iDEC) that uses well gas as fuel to generate electricity and hydraulic power. TES has sold 30+ iDEC product solutions.

# TES-i Industrial Digital Engine Controller

- Small Form Factor ( 6.75 x 9.25 x 2.3" )
- Low Weight ( 4 lbs. )
- Multiple Mount Options
- IPx9K rated connectors
- Ethernet or Serial 422/485 Control
- Triple Processor Architecture
- 8MB Flash Memory
- 1MB Non-Volatile Memory

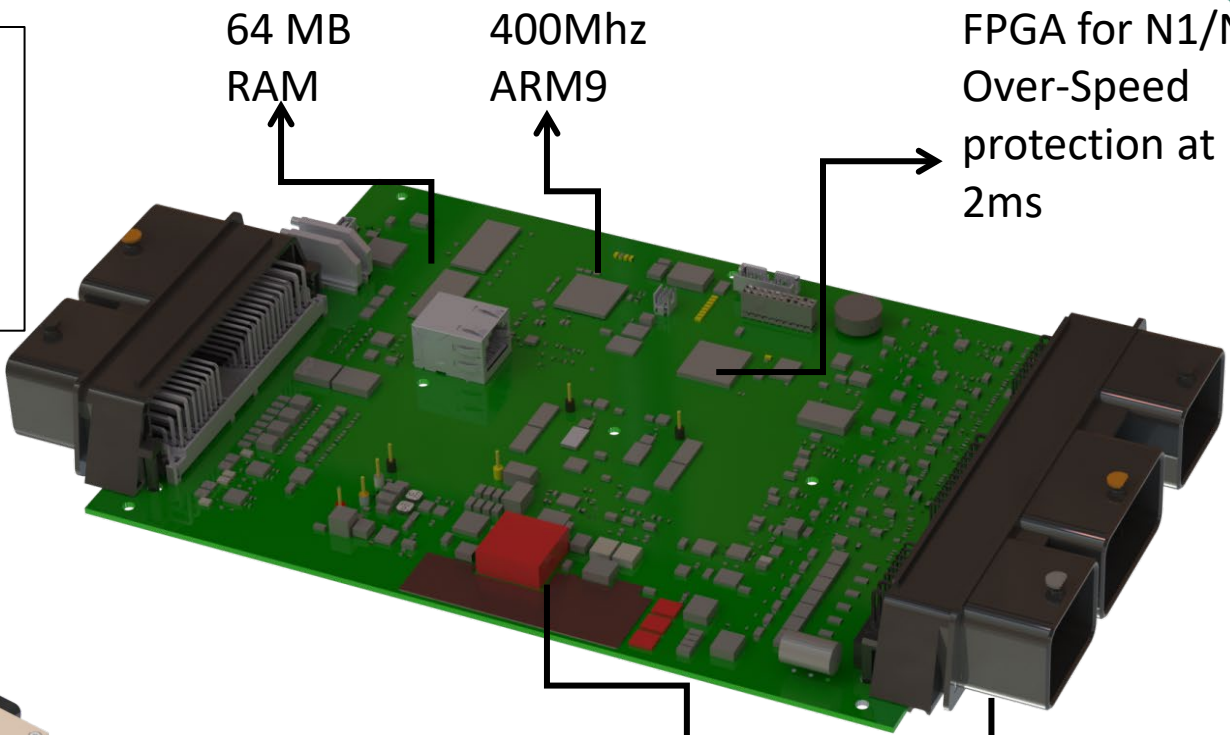

64 MB  
RAM

400Mhz  
ARM9

FPGA for N1/N2  
Over-Speed  
protection at  
2ms

Quick Status LEDs

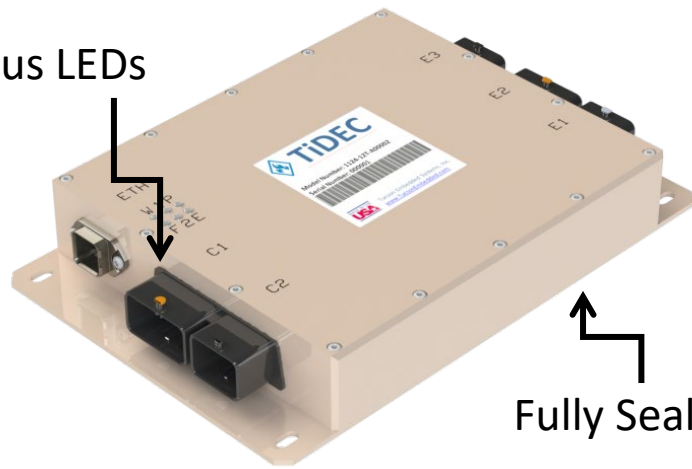

Fully Sealed Enclosure

Wide Input  
(18-32VDC)  
Power Supply

Sealed, Cost  
Effective  
Connections



# TESseract – Aviation FACE Computer

TESseract, in partnership with CES and FlightWire, is a scalable off-the-shelf solution for flight-capable UAS computers hosting FACE architectures. A rapid integration solution for FACE developers and FACE platforms, TESseract grows as needs change, from a 2-card system to a fully redundant 8-slot solution. The processor is loaded with a FACE common operating environment to support a wide range of avionics, embedded development, or real-time safety-critical operations.

Rugged for harsh environments, it features a wide range of input power supplies, a fully sealed conduction-cooled chassis, and MIL-STD-810G compliant components for the most extreme UAS environments. TESseract's FW-3x-VNX-800 VNX 19mm card provides a robust, redundant, EMI-protected, and flight-capable networking bus. Based on proven AS5643/IEEE-1394b (Mil-1394) standards and hardware, our implementation provides deterministic gigabit speed and triple redundancy.



*TESseract and Mil-1394 VNX Communication Card*

# IOT and Smart Cable



Developed for the mining Oil and Gas industry, wireless sensors were used to instrument a mine and fracking sites. The data to capture in these environments is endless. Providing real-time informative data is priceless.

- Self Healing Mesh Radio Network with GPS tracking with remote sensing and control
- Expandable and Rugged
- Monitors and Controls hundreds of deployed assets
- 802.15.4 ZigBee Technology
- 1 Control Gateway with Multiple Nodes
- Deployed hundreds of units for international mining company

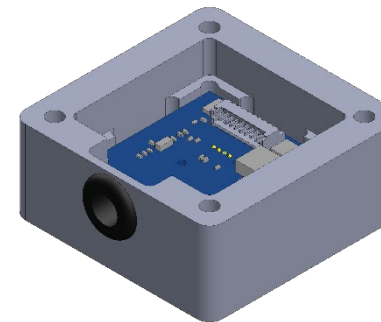

# Zigbee Sensor System (“Site Advise”)



TES developed the ZigBee sensor system (“Site Advise”) to manage various pieces equipment within a mine for [Modular Mining Systems, Inc.](#), the Leader in Mine Management Systems. The Asset Nodes are designed for rugged environmental conditions.

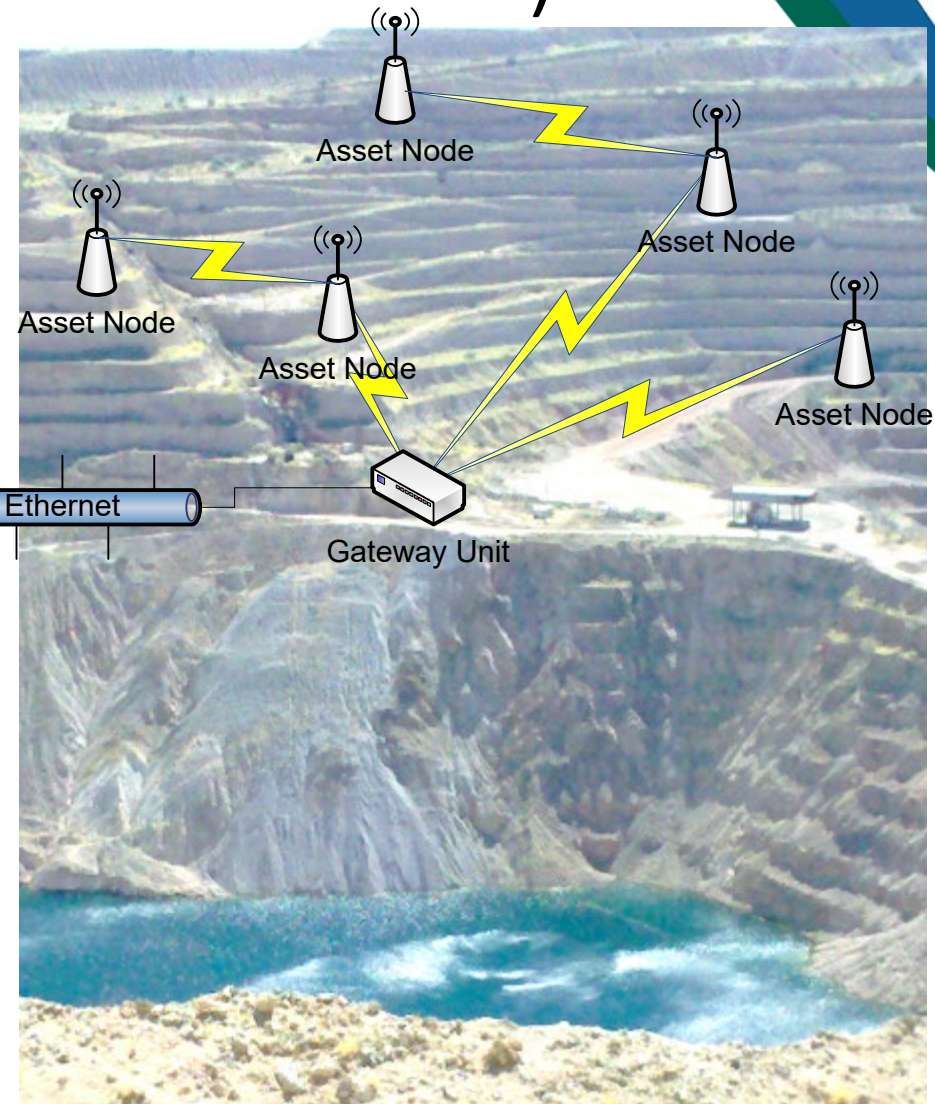
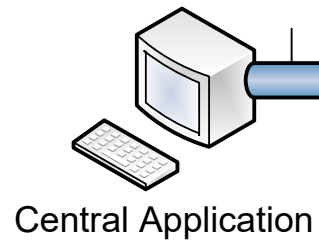

“The possible uses are virtually limitless,” states Michael Lewis, Modular VP of Sales and Marketing. “With this module, you can ensure that your assets are in the right place, at the right time, performing the right task.”





# HOST HARMONY

## Hardware Open System Technologies (HOST)

### **HOST HARMONY:**

- Conformance Test Station for NAVAIR's HOST standard
  - Developed under SBIR (Ph-I & Ph-II & Ph-III)
- Supports Conformance Test and CVM Generation
- Direct interface for OpenVPX Test Hardware
- Test Procedure Development Environment for OEMs (Tier 3 development)
- Open and extensible data formats
- Extensible functionality through plugins
- Cross platform and supports web delivery
- Auto documentation of artifacts (MS-Word)
- DOORs Integration



### **Benefits:**

- Streamlined Conformance Process
- Multi-Organization support with built-in security
- Web based tools to evaluate HOST conformant products
- OEM tool development conformance verification artifacts (Model, Traces, Docs, Tests)
- Full traceability eliminates ambiguity

# Tactical Radio Control System (TRCS)

**Objective:**

To design, develop, manufacture, and verify a custom Military Radio Network from one command to many vehicles over an RF network.

**Outcome:**

- Develop and Deliver 20 prototype units
- Configure and Control IP Mesh Radio Network with remote messaging and HMI Display
- Controls 802.11 IP Technology on various encrypted frequencies
- Enclosure for 19" Rack with removable custodial drawer
- Power Management and Battery Backup Sub-System with 30 Day Cryptographic Key Hold
- Designed for -30 to +70° C
- Designed for MIL-STD-810G and MIL-STD-704F
- Perform SIL Functional and Field Demonstrations

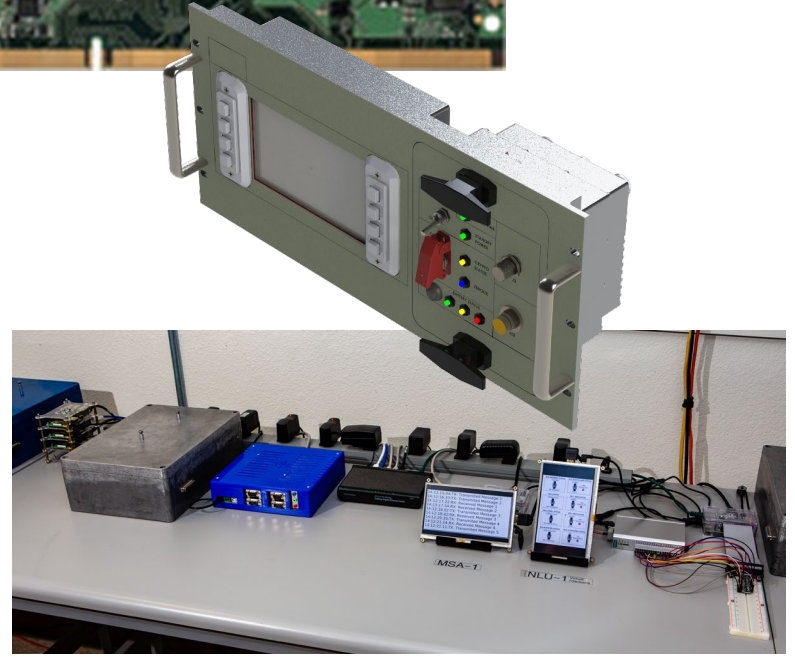



# SBIR/STTR Efforts (Past and Present)

- N68335-18-C-0274, Phase I & II & III – Hardware Open Systems Technology (HOST) Conformance Tooling
- N65538-06-M-00061, Phase I – Common Reusable Open Architecture Under-Sea Warfare Mission Package Infrastructure- Capability Driven Architecture (CDA)
- N162-101, Phase I – Future Airborne Capability Environment (FACE™) Transport Protocol Mediation and Integration
- A181-080-1240, Phase I – Common Avionics Engine Interface – TES-i is a subcontractor to Management Sciences, Inc. (MSI) for the FADEC data model interface
- A16-043-1232, Phase I – Intelligent Agent Based Automated ISR Collection and Optimization - Radiant Focus



# Contract Vehicles

## **AMCOM Express**

AMCOM Express is a Blanket Purchase Agreement (BPA) under the U. S. Army Contracting Command, Aviation and Missile Command (AMCOM). This includes services of information, analyses, evaluations, recommendations, training, and technical and management support.

## **Battlefield Systems (BSES)**

The BSES program focuses on providing support to new technologies and provide systems and computer engineering resource services to SED, and AMRDEC under the U.S. Army Software Engineering Directorate and the Army Research, Development and Engineering Command (USA RDECOM).

### ***Software Life Cycle Development (SLCD)***

The SLCD support will span the entire life cycle of systems for which S3I has responsibility.

### ***Hardware in the Loop (HWIL) Aviation Systems***

The HWIL Aviation Systems is to provide full life cycle support for high fidelity aviation system simulators, HWIL capabilities, and associated test tools.



TES-i



# Contract Vehicles (cont'd)

## **Vertical Lift Consortium (VLC)**

The VLC is a collaboration of conventional and unconventional government contractors working with the US Government to develop and transition innovative vertical lift technologies to meet the increasing needs of warfighters. Utilizing the VLC Other Transaction Agreement (OTA), allows for multi-level industry collaboration to speedy execution. Under this Agreement, the Government, in conjunction with VLC and with its non-government members , performs a research and development program designed to create prototype aviation technologies.



# TES-i Patents and Trademarks

- **Systems Engineering Patents**

- **Capability Driven Architecture (Patent Issued):**

- A method and apparatus is presented for using multiple device specific interface protocols for communicating with a platform, where each of the devices comprises a set of parameters. For each parameter of each set of parameters a function call is established to set the parameter for each of the devices that enable the parameter. Using each function call, the plurality of object specific interface protocols is then transformed into a non-device specific interface protocol for communication with the platform.

- **Engine Patents (50% owned by TES-i) (“Cruz Control”, “CruzFrac”, “CruzGen”)**

- **MULTI-COMPATIBLE DIGITAL ENGINE CONTROLLER (Patent Issued)**

- A digital engine controller compatible with multiple variants of gas turbine engine is programmed to receive identification of a variant of gas turbine engine coupled to the digital controller and thereafter to automatically determine and adjust inputs to the engine, according to the received identification of engine variant, to meet user-specified output.

- **PUMP-ENGINE CONTROLLER (Patent Pending)**

- A system controller manages a gas turbine engine driving a pump directly or indirectly coupled to the engine. The controller is programmed to automatically determine and adjust inputs to the gas turbine engine in order to cause the pump to produce a user-specified hydraulic output.

- **GAS TURBINE ENGINE OVERSPEED PREVENTION (Patent Issued)**

- A controller for a gas turbine engine is configured to respond to one or more prescribed engine overspeed conditions. Rather than shutting the engine down, the controller substantially reduces N1 airflow and substantially concurrently activates one or more engine igniters.

- **CONTROLLER ASSEMBLY FOR SIMULTANEOUSLY MANAGING MULTIPLE ENGINE/PUMP ASSEMBLIES TO PERFORM SHARED WORK (Patent Pending)**

- A pumping system includes a pump array of multiple pump-engine assemblies. Each pump-engine assembly comprises a pump and a gas turbine engine driving the pump. A manifold is coupled to the pumps. A master controller is coupled to each of the pump-engine assemblies either directly or via one or more intermediate controllers. The master controller and any intermediate controllers are collectively programmed to respond to user input including a desired hydraulic output at the manifold by automatically calculating and applying inputs to the individual pump-engine assemblies to provide the desired hydraulic output.

- **SYSTEM AND METHOD FOR AUTOMATICALLY CONTROLLING ONE OR MULTIPLE TURBOGENERATORS (Patent Pending)**

- At least one controller manages a gas turbine engine driving a generator directly or indirectly coupled to the engine. The controller is programmed to automatically determine and adjust inputs to the gas turbine engine in order to cause the generator to produce a user-specified electrical output. Multiple sets of generator, engine, and controller may be used, in which case a master controller individually manages the other controllers to collectively provide the a user-specified electrical output.



# Conclusion

Utilizing a wide range of capabilities, our highly experienced engineering team tackles your mission and safety-critical system, software, and electronic hardware challenges with proven technologies customized to meet your unique requirements. We specialize in enterprise and embedded hardware and software, supporting accelerated integration, automated testing, and meeting rigorous FAA and Department of Defense (DoD) standards

TES-i is a full-service firm, working with you from concept to requirements, through design, development, prototype, production, integration, and test to create the ideal solution on your timeline and budget.

